



CAREFUL環境關聯物質管控標準: Cd<5ppm; Pb<50ppm; Hg:ND; Cr6+:ND

ISO9001-2008
Certificate No:02411Q20838R2M

Defer to: **SONY/SS-00259** ; SAMSUNG/OQA-2049 ; **MICROSOFT/H00594** ; FOXCONN/EPI12 ; **HP/HX-00011-00...**

承 認 書

SPECIFICATION FOR APPROVAL

客户名稱 CUSTOMER	LEPCOS
品名規格 DESCRIPTION	F2 RH 14.2×15×6.7
客户料號 CUS. P/N	
提出日期 DATE	May.14. 2020.
編 號 SERIAL NO.	KF 20051430041

出 圖 DRAWING			承 認 CUSTOMER APPROVE	
發行 MADE	復 核 CHECKED	確 認 APPROVED		
DATE: 2020年05月14日				



科峰集團

CAREFUL GROUP

www.careful.cn
e sales@careful.cn
e info@careful.cn

湖州科峰磁業有限公司
HuZhou Careful Magnetism Co.,Ltd.

浙江省湖州市含山工業區 313014
Hanshan Industry Zone Huzhou Zhejiang

TEL: 00 86 - 572 - 367 0006 / 367 2766
TEL: 00 86 - 572 - 367 0006 / 367 2766

FAX: 00 86 - 572 - 367 0025
FAX: 00 86 - 572 - 367 0025

嘉興科峰磁電有限公司
JiaXing Careful Magnetism & Electron Co.,Ltd.

浙江省嘉興市河山工業區 314512
Heshan Industry Zone Jiaxing Zhejiang

TEL: 00 86 - 573 - 8867 1616 / 8867 0988
TEL: 00 86 - 573 - 8867 1616 / 8867 0988

FAX: 00 86 - 573 - 8867 1515
FAX: 00 86 - 573 - 8867 1515

承認書

SPECIFICATION FOR APPROVAL

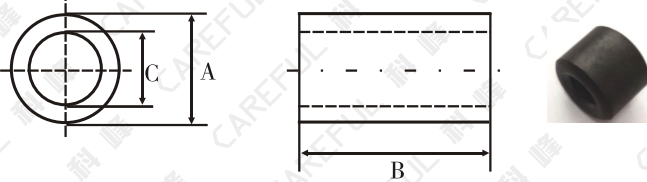
客戶名稱 CUSTOMER	LEPCOS	日期 DATE	2020.05.14.
規格 ITEM	F2 RH 14.2×15×6.7	編號 SERIAL NO.	KF 20051430041
1.1. 形狀尺寸(單位/毫米): SHAPE & DIMENSION(unit/mm):	1.2. 實物圖: The Sample::	A	14.2 ± 0.5 mm
		B	15 ± 0.5 mm
		C	6.7 ± 0.4 mm
		D	
		E	
		F	
		G	
		H	

2. 電氣性能檢測項目: ELECTRICAL REQUIREMENTS:

<input type="checkbox"/> L		TEST FREQ	KHZ MHZ
<input type="checkbox"/> Q		TEST FREQ	KHZ MHZ
<input checked="" type="checkbox"/> Z	Z1= 45Ω MIN	25 KHZ	100 MHZ
	Z2= 100Ω MIN	100 KHZ	100 MHZ
	Z3=	/ KHZ	/ MHZ
	Z4=	/ KHZ	/ MHZ
溫度 TEMP	℃	濕度 HUMIDITY	%
線組 WINDING	Φ0.5x0.5TSx100L(mm)		

測試儀器 TEST INSTRUMENTS

- Q-METER:
○HP 4342A ○MQ-172
- L.C.R. METER:
○HP 4284A
- IMPEDANCE ANALYZER:
○HP 4396B ○HP 4191A ○E4991A
○Agilent 16092A-TESTFIXTURE
- L-METER:
○TH 2817A
- DIGITAL MINI-OHMMETER:
○VP2941A

3. 外觀標準: 依下表對照檢索: THE LIMIT OF BREAKAGE: CHECKED BELOW:

OD (mm)	0~5	5.1~10	10.1~15	15.1~20	20.1~25	25.1~30	30.1~35	35以上
缺陷面积 Defect area (mm ²)	≦1	≦2	≦3	≦4	≦5	≦6	≦7	≦8
缺陷个数 Number of defects (≦)	1	2	3	3	3	3	2	2



4. 材質特性 MATERIAL CHARACTERISTICS

材料牌號 Material	初始磁導率 Initial Permeability	比損耗因子 Relative Loss Factor	比溫度係數 Relative Temperature Coefficient	飽和磁通密度 Saturation Magnetic Flux Density	剩磁 Remanence	矯頑力 Coercivity	居裏溫度 Curie Temperature	電阻率 Electrical Resistivity	密度 Density
Unit symbol	μ_i	$\tan \delta / \mu_i$	$\alpha \mu_i \gamma$	Bs	Br	HC	Tc	ρ	d
	±20%	$\times 10^{-6}$	$\times 10^{-6}$	(MT)	(MT)	(A/m)	(°C)	($\Omega \cdot m$)	g/cm ³
F2	650	20 (0.1MHz)	2-5	260(1600A/m)	150	35	>140	>10 ⁵	4.6

A	首版First Edition	2020-05-14	Rosie
版本Rev.	變更內容說明Description of Change	日期Date	姓名Name

檢驗數據

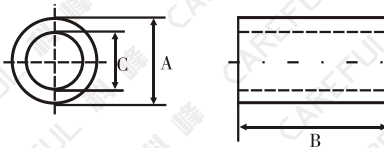
INSPECTION DATA

客戶名稱 CUSTOMER	LEPCOS		日期 DATE	2020.05.14.	數量 QUANTITY	10PCS
編號 SERIAL NO.	KF 20051430041		形狀尺寸(單位/毫米): SHAPE & DIMENSION(unit/mm):		實物圖: The Sample:::	
規格 ITEM	F2 RH 14.2x15x6.7					
線組 WINDING	Φ0.5x0.5TSx100L(mm)					
測試頻率 TEST FREQ	Z1= 25 KHZ 25 MHZ	Z2= 100 KHZ 100 MHZ				
	Z3= / KHZ / MHZ	Z4= / KHZ / MHZ				
溫度 TEMP	℃	濕度 HUMIDITY	%			

項目 TEST ITEM	電氣性能 ELECTRIC CHARACTERISTICS						尺寸(單位:毫米) DIMENSION(unit:mm)					
	Q	L(μH) (MH)	Z1(Ω)	Z2(Ω)	Z3(Ω)	Z4(Ω)	A	B	C	D	E	F
			45	100			14.2	15	6.7			
+			/	/			0.5	0.5	0.4			
-			0	0			0.5	0.5	0.4			
1			60.2	131.6			13.96	14.90	6.66			
2			59.6	130.0			13.98	15.03	6.69			
3			59.8	130.8			13.89	15.00	6.73			
4			60.4	131.2			13.85	14.99	6.68			
5			60.0	131.4			13.86	14.86	6.70			
6			60.2	130.6			13.98	14.93	6.75			
7			59.6	130.2			14.04	14.88	6.72			
8			59.2	131.6			14.07	14.95	6.60			
9			60.4	131.0			14.06	14.92	6.68			
10			60.2	130.4			14.03	14.87	6.72			
\bar{X}			59.96	130.88			13.97	14.93	6.69			
Y/N			Y	Y			Y	Y	Y			

測試儀器:
TEST INSTRUMENTS:
HP 4191A

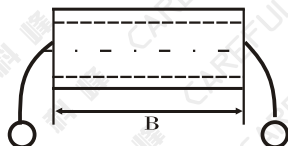

檢驗
INSPECTED

汪建琴

復核
CHECKED



確認
APPROVED



A	首版First Edition	2020-05-14	Rosie
版本Rev.	變更內容說明Description of Change	日期Date	姓名Name

阻抗 - 頻率曲綫

IMPEDANCE V.S FREQUENCY (Z-Y)

客戶名稱 CUSTOMER	LEPCOS	日期 DATE	2020.05.14.
規格 ITEM	F2 RH 14.2x15x6.7	編號 SERIAL NO.	KF 20051430041

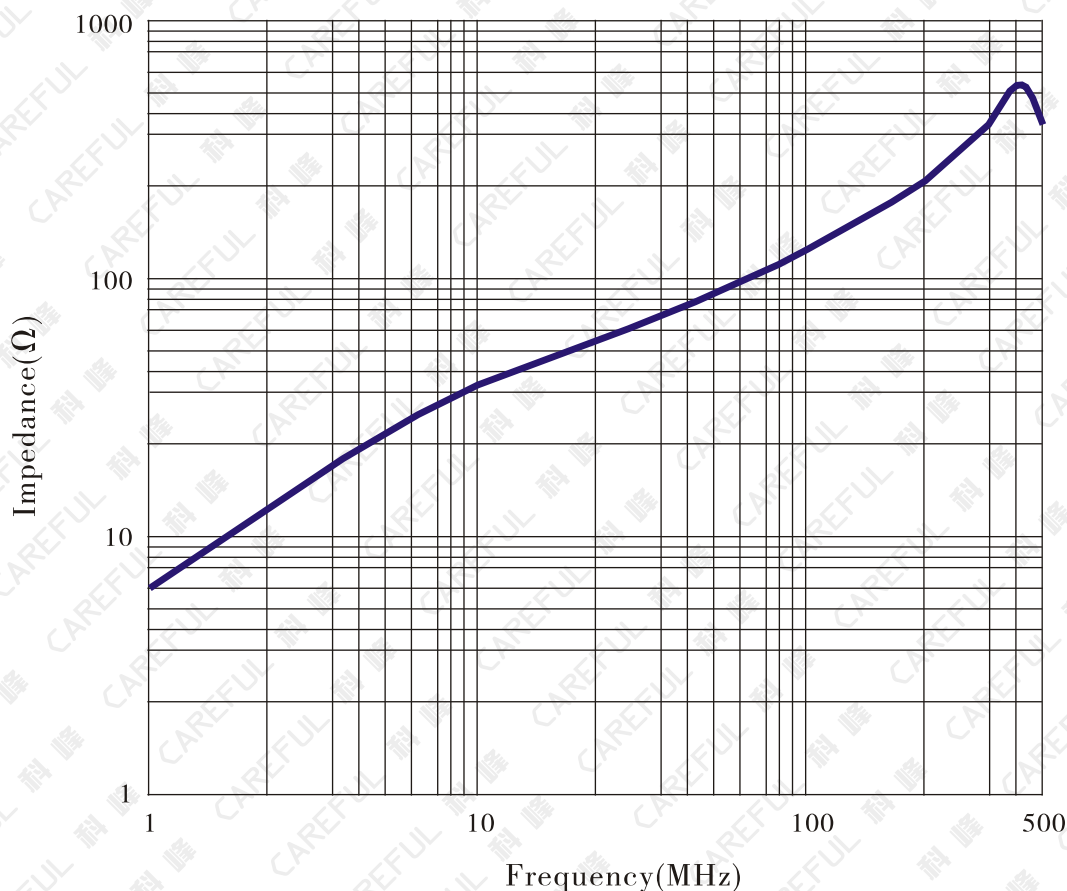

測試條件:
TESTING CONDITION:

1. 測試儀器: HP 4191A
Testing Equipment:
2. 測試頻率區間: 1-500MHz
Testing Frequency Range:
3. 測試綫組: Φ0.5x0.5TSx100L(mm)
Testing Coil Specification:

說明Note:
本承認書在客戶收到7天之內, 須簽章返回, 逾期視為默認。
The Specification Approval is required to be sent back to the supplier with customer's chop or signature on it within 4 days after receiving it, or we will take it as approved by customer automatically.

測試 TESTED	復核 CHECKED	確認 APPROVED
汪建琴	周紀君	沈學泉

A	首版First Edition	2020-05-14	Rosie
版本Rev.	變更內容說明Description of Change	日期Date	姓名Name